

2021

Environmental, Social and Governance Report

Delivering on our commitment to the future.

rackspace
technology®



Rack Gives Back™
FANATICAL SUPPORT™ FOR THE COMMUNITY

A message from our Chief Executive Officer

To all our constituents — customers, suppliers, employees, shareholders and our communities:

I'm very pleased to write to you in what is our first Environmental, Social and Governance (ESG) Report. While ESG has been discussed in the financial community for a decade or more, 2021 saw it gain tremendous traction. In the midst of a global pandemic, corporations are raising the bar on responsibility in the critical areas categorized as ESG in an effort to maintain connections with their customers, employees and communities.

At Rackspace Technology®, we're committed to helping companies around the world grow through the use of technology. Along with this commitment comes a responsibility to our customers, our employees and the communities in which we work. We're not just a great company and a great investment, but also a careful and attentive caretaker of the resources with which you have entrusted us, and of the world in which we live.

ESG is rooted in our heritage

While this is our first comprehensive ESG report, I want to assure you that ESG is not new to Rackspace Technology. This company was built on a foundation of commitment to our communities, care for our employees and stewardship of the planet and its resources. Our headquarters in San Antonio illustrates visible and tangible evidence of that fact. In 2005, the Windsor Park Mall in the City of Windcrest, a suburb of San Antonio, closed. Years of neglect and urban decay resulted in its demise, costing the surrounding community jobs and tax revenues. It sat empty and abandoned.

At the same time, Rackspace Technology was expanding dramatically and needed a new headquarters to call home. After an exhaustive search, in 2007, we committed to transforming the abandoned mall into more than one million square feet of office and data center space.

Today, the building is a physical representation of our values. It speaks to our desire to build a great company, and to our desire to help others make our community a better place for everyone. As a LEED gold-certified building, it speaks to our commitment to the environment. In fact, conversion of the mall into our headquarters included several ahead-of-their-time features, such as a rainwater cistern and dual-flush toilets. Space in the mall was even used house more than 3,000 refugees in the aftermath of Hurricane Katrina.

I tell you all of this not to recount past history, but rather to emphasize that ESG principles have been rooted in the culture of Rackspace Technology from the very beginning. ESG is not a nice-to-have element of our business model. We aren't putting our ESG stake in the ground because it's what everyone else is doing today. Instead, as you'll see, ESG is part and parcel to our existence as a company.

Our methodology

When we became publicly traded, I created a cross-functional team to evaluate our ESG practices across the company, compare them with other respected public companies, and recommend both the proper level of reporting and transparency as well as areas where we can improve going forward.

As part of this initiative, we identified priority areas within each of the three pillars of ESG: Environmental, Social and Governance. We then reviewed our current practices and documented them for this report. The ESG team also shared recommendations with our Board of Directors, and we are in the process of implementing certain improvements that will advance our ESG goals.



Kevin Jones

Chief Executive Officer, Rackspace Technology

This will not be a once-and-done, or even an annual exercise. Continuous improvement in ESG will be a consistent part of our operating plan. Our ESG efforts will be reviewed regularly in the management system of the company, as well as in our board meetings, and will remain a high priority for me, our board members and every one of the company's leaders. This project has no end. To be world-class in this area, we need to continuously evaluate, prioritize and invest in ESG initiatives.

Social

I want to lead off with Social, the “S” in ESG, because that is an area where Rackspace Technology really shines. As I highlighted in our annual report to shareholders earlier this year, we have a lot to be proud of in this regard.

Our unique employee culture is consistently recognized externally across the globe. We have been honored by the Great Place to Work Institute in the U.S., India, Mexico, the Netherlands, Singapore, Switzerland, Australia, the United Kingdom and Hong Kong. We've also attained a score of 100% on the Human Rights Campaign's Corporate Equality Index, and were named a Best Place to Work for LGBTQ+ Equality. And we've been named a Best for Vets employer by Military Times magazine, a Top 50 Best Workplace for Latinas in the U.S. by Latina Style Magazine, and a Best Place to Work for Moms, Dads, and Parents Working Remotely by Parents@Work.

Diversity, Inclusion and Belonging are critically important to our culture. It is one of my highest priorities to ensure that the decision-making voices within the company bring a variety of perspectives, experiences and cultural points of view to the table. Accordingly, in late 2020, we hired a Senior Director of Global Diversity, Inclusion and Belonging to develop programs that drive the growth of a diverse and inclusive workforce around the world.

To foster an inclusive and welcoming company culture, we have several Racker Resource Groups. (The term “Racker” refers to a Rackspace Technology employee.) Examples include Together with Pride (for members of the LGBTQ+ community), POWER (the Professional Organization for Women's Empowerment at Rackspace), and RISE (Rackspace Inclusive Support and Empowerment for Black, African and African American cultures), among others. In total, there are nine such groups that meet regularly, bring ideas and concerns to the leadership team, and generally make members of their community feel welcome, heard and appreciated at Rackspace Technology.

The act of giving back to our community is in our DNA. Since 2008, the Rackspace Foundation has been supporting underserved San Antonio-area schools through charitable grants, and all Rackers are provided with a minimum of 40 hours of paid volunteer time off so they can donate their time and talent to their local communities.

Environmental

Our environmental strategy is to give more than we take from our planet and to support innovative technologies that change the energy industry for the better. Our Global Energy Policy calls for this to be accomplished through renewable energy, conservation and advocacy. We achieve this through direct efforts to reduce energy consumption, rather than purchasing carbon offsets, as we believe this strategy has a much more profound impact on the environment.

We have prepared a greenhouse gas (GHG) emissions inventory every year since 2008 for all of our operations, worldwide. This provides an annual baseline so we can better understand our footprint and identify high-impact efficiency projects that help us conserve resources.

As a result, over the past several years, we made several steps forward, including our commitment to purchase 100% renewable energy in two major U.K. locations; deploying energy-saving smart building automation systems in five locations worldwide — including our corporate headquarters in San Antonio; finding creative ways to minimize



Rack Gives Back

Rackers in Germany collect food from supermarkets for Münchner Tafel, a charity that helps people in need.

waste on our campuses; and enhancing our ability to manage light, heat and cooling zones in our facilities based on operational demand.

We also participate in the Climate Change Agreement (CCA), which is a U.K. voluntary scheme for energy-intensive industries, and we have responded to the CDP Climate Change survey every year since 2011. This year, we are making all of the data in that report available to investors, which is an important step to increase our transparency on environmental matters with investors.

Governance

A strong governance framework is foundational to our Racker culture, and provides the underpinnings of how we as a company treat our employees, customers and even our competitors.

Our Corporate Governance in our internal operations and external-facing activities is rooted in The Rackspace Technology Code of Conduct and Business Ethics. All employees must acknowledge this code by signature when they join the company. Our code covers important governance topics, including compliance with laws, rules and regulations; discrimination and harassment; intellectual property protection; and competitive behavior, among others. To underscore the importance of this code, we require that all Rackers complete a yearly Code of Conduct training program to ensure continued awareness and compliance with these policies.

In 2017, we implemented a Whistleblower Policy that encompasses the treatment of complaints about accounting and auditing matters, deceptive financial practices, policy violations and illegal activity. This policy provides whistleblowers with protections that include anonymity and anti-retaliation, and ensures that reported violations are investigated swiftly and thoroughly.

A commitment to continuous ESG improvement

Going forward, a strong ESG governance regime will be implemented to ensure we continue to increase our ESG efforts year-by-year. In the near-term, we have already established an ESG Steering Committee, which was tasked with leading this effort to launch our first ESG report. Going forward, this group, which includes leaders from all areas of the company, will be responsible for coordination of corporate-wide ESG efforts. They will manage the day-to-day implementation of our ESG initiatives.

We have also launched an Executive ESG Committee. Members of this committee will make strategic proposals to the Board, with direct oversight of the ESG Steering Committee.

Finally, Board of Director oversight will play a critical role in the success of our ESG program. In each of our board meetings in 2021, we provided the Board with visibility into our ESG initiatives, and the Board will continue to review our ESG roadmap moving forward.

As I noted, our goal is to ensure steady progress to improve our ESG efforts year over year. This is too important to our company, our community and, in fact, our world to be a check-the-box exercise. Ultimately, it's what will make this planet a better place for all of us. And so, it's worthy of 100% commitment from the entire Rackspace Technology team.

Sincerely,



Kevin Jones
Chief Executive Officer



Contents

Corporate Overview	4
Delivering on our mission each and every day ...	5
Materiality Assessment	7
Social Responsibility	9
Giving back to our communities	10
Diversity of thought sparks innovation	11
Racker Resource Groups	12
Employee engagement	13
Career development	15
Our focus on equality	17
An update on COVID-19	18
Environmental	19
Our conservation strategy	20
Environmental sustainability is a core focus of our partnerships	22
Governance	23
Board oversight of our sustainability efforts ...	24
Our approach to risk management	24
Data privacy and cyber-security	25
Rackspace Technology Code of Conduct and Business Ethics	27
Indices and Policies	29
Sustainability Accounting Standards Board (SASB) Index	30
Task Force Climate-Related Financial Disclosures (TCFD) Index	31
Forward-looking statements	32
Our policies and statements	32



Corporate overview

Corporate overview

Delivering on our mission each and every day

We serve customers in more than 120 countries, including more than half of the Fortune 100. And with cutting-edge, interconnected data centers strategically located in the world's most influential technical and financial markets, we provide our customers with the global reach, scale and organizational agility they need, wherever they are and whenever they need it.

Our mission

While technology is increasingly complicated, our mission is very straightforward and clear: We strive every day to embrace technology, empower customers and deliver the future.



Embrace technology

We develop and explore new technologies while mastering those most important to our customers.



Empower customers

We help customers achieve their business goals by working with them every step of the way.



Deliver the future

We prepare our customers for the future faster than they can do it themselves.

Our customer engagement approach: Solving Together™

The technology world changes quickly, and sometimes, quite literally, overnight. We work to help customers stay ahead by establishing a deep understanding of each customer's needs, then working with them to bring their visions to life. We create the best solution for each customer's business today, and give them confidence that they'll be able to deliver tomorrow.

We constantly embrace, develop and master new technologies to ensure our customers have access to the latest and best capabilities. We utilize technology and automation to drive success for our customers, partners and ourselves. We empower our customers, and we deliver the future quickly, cost-effectively and efficiently.

We solve more than workload problems; we create business advantages. Our multicloud solutions expertise means our customers are empowered to work faster, smarter and ahead of what's next.

We are Rackspace Technology. Our expertise powers each customer's advantage.

We put technology to work:

We're reinventing what's possible today, unlocking potential and creating new solutions that can drive what technology — and the world — can do next.

We empower customers with our expertise and solutions:

Our extensive expertise and our track record of experience means we're defining the way forward when it comes to multicloud solutions.

We deliver the future, faster:

We're agile and dynamic, delivering breakthrough solutions and services that are changing the expectations of what technology can do.

We are obsessed with customer success:

Fanatical Experience™ represents our obsession with customer success. It's what's defined us over the years and drives the loyalty of those we work with.

A thriving workplace culture built on employee satisfaction

Rackspace Technology is consistently recognized as a great place to work.



**Achievers 50
Most Engaged
Workplaces**

**Best
Workplaces
in Mexico**

**Best Place to
Work
for Latinas in
the U.S.**

**Best Place to
Work
for Moms**

**Best Place to
Work
for Dads**

**Best Place to
Work
for Parents
Working
Remotely**

**Best Place to
Work
for LGBTQ+
Equality**

**Great Place to
Work
certified in
Mexico and India**



In 2007, we committed to transforming a defunct shopping mall into our LEED gold-certified headquarters with more than one million square feet of office and data center space.



Materiality Assessment

Materiality assessment

Through our engagement with a third-party ESG advisory partner and polling of nine internal departments that represent a wide cross section of roles and operations at Rackspace Technology, we've identified the following specific areas of high priority for our ESG initiatives:

Social:

- Diversity, inclusion and belonging
- Employee engagement and satisfaction
- Employee recruitment, development and retention
- Discrimination and harassment

Environmental:

- Energy management and usage
- Renewable energy usage

Governance:

- Data privacy and cybersecurity
- Managing systemic risks from technology disruptions
- Business ethics and code of conduct
- Intellectual property protection and competitive behavior
- Whistleblower programs

Oversight and accountability for these initiatives

Moving forward, we will establish oversight for these initiatives at three levels: Board oversight, Executive ESG Committee oversight and our internal ESG Steering Committee:

Board oversight

The Board will contribute to oversight of ESG initiatives by providing advice and guidance on ESG management and the strategic roadmap for ESG efforts.

Executive ESG Committee

Our senior leadership will review strategic proposals with the Board and oversee the execution of decisions, with direct oversight of the ESG Steering Committee.

ESG Steering Committee

This cross-functional team of Rackers will assist with policy planning, the coordination of company-wide ESG efforts, managing the day-to-day implementation of company initiatives and maintaining accountability for our performance.

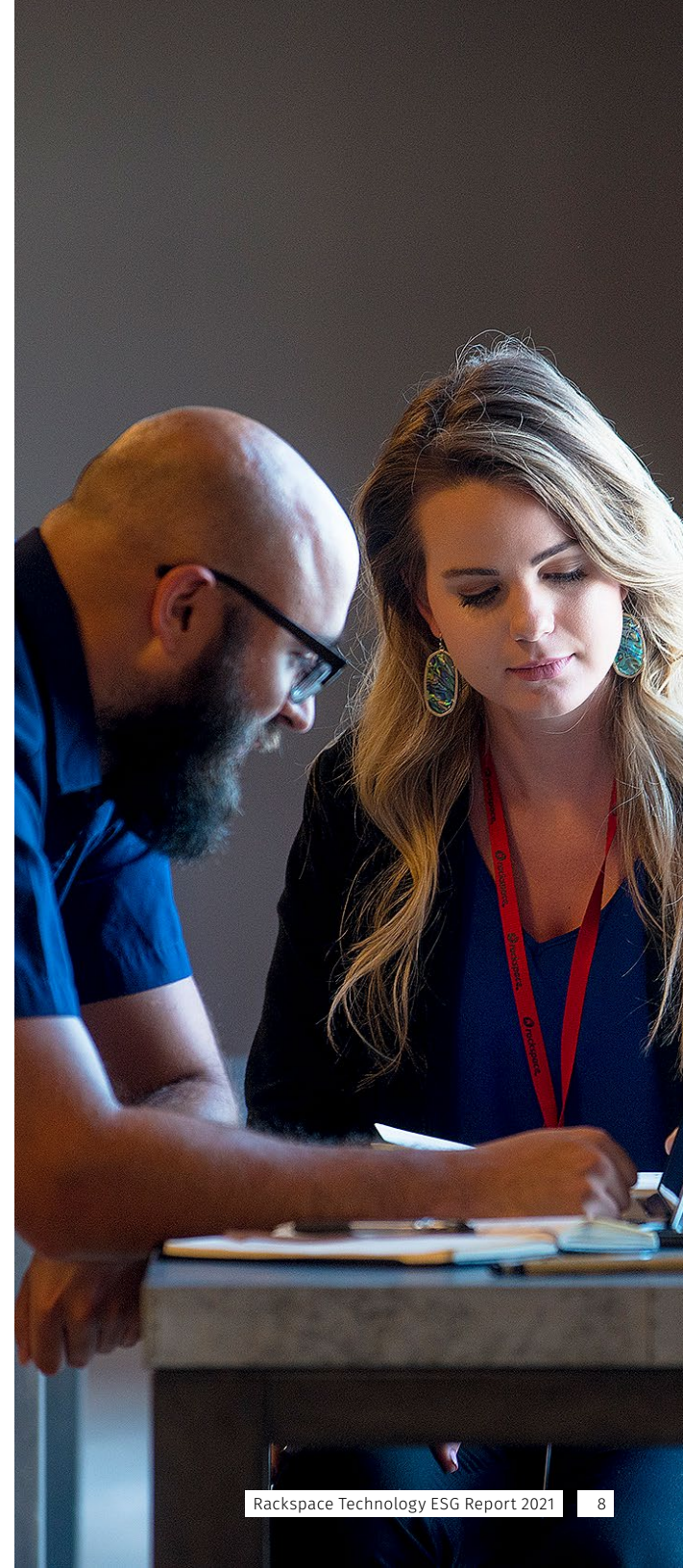



 Rack Gives Back

A Racker in San Antonio directs traffic at our annual Thanksgiving Food Drive, where thousands of families have been fed through our support of the San Antonio Food Bank.

Social Responsibility

Social responsibility

Giving back to our communities

As a company built on its reputation for service, we know that at the heart of every service is people — those who deliver our services, and those counting on our services to deliver the future. And surrounding both of these groups are the communities in which we all live.

For over two decades, Rackers have nurtured a robust commitment to our customers, our communities and each other. As you'll see in the next pages, our commitment to social responsibility runs deep — from our internal commitments to diversity, inclusion and belonging, to our financial and volunteer support of our communities, and the commitment of Rackspace Technology leadership to engage, enrich and develop every Racker to their maximum potential.

Rack Gives Back

Rack Gives Back

Our Rack Gives Back program enables all Rackers to share Fanatical Experience™ with the communities in which we live, work and play. Every year, Rackspace Technology grants each Racker a minimum of 40 hours of volunteer time off as part of their benefits. Rackers are free to volunteer, individually or as a group, at organizations and events of their choosing.

rackspace FOUNDATION

Rackspace Foundation

Rackers have a strong desire to serve our customers, fellow Rackers and the community around us. We believe in being more than just a good neighbor; supporting and investing in our communities is part of who we are. Officially launched in 2009, the Rackspace Foundation is a way for us to take this passion for service to the next level with our neighbors in a meaningful ways.



We take a place-based approach to community investment. Rather than focusing on a single cause across many geographic regions, we are committed to providing holistic support for the schools and students in our immediate neighborhoods. For example, at our headquarters location, we have adopted seven schools in San Antonio, where we fund important programs that help meet basic needs and give students a well-rounded education. Through these programs, we're building safe spaces in which students can find their passions, express their identities, ask questions, nurture creativity and explore their true potential.

Corporate Partners for Racial Equity

In 2021, CEO Kevin Jones was one of 12 San Antonio business leaders who joined efforts to form the Corporate Partners for Racial Equity with a mission to improve racial equity in the community. Members of this coalition took a close look at disparities in San Antonio and recognized how complex and rooted they are. Using input from more than 30 local and national leaders and experts, this coalition has defined three focus areas: Equitable Education, Economic Opportunity and Safety and Justice. Joint contributions totaling \$13.8 million over the next five years will support these initiatives.

Changing the world in 2020 through volunteerism, charitable contributions and the mission of the Rackspace Foundation



14,000

volunteer hours



\$300k

raised in support of pandemic relief efforts



1,000

families fed by our annual Thanksgiving Food Drive



\$31k

donated by Rackers to 17 food banks





Racker spotlight:
Chinten Parikh

Senior Director, Global Diversity,
Inclusion & Belonging

Social responsibility:

Diversity of thought sparks innovation

A message from Chinten Parikh, Senior Director, Global Diversity, Inclusion & Belonging:

Rackspace Technology is known throughout the industry for our diverse, inclusive and vibrant company culture that cultivates a sense of belonging, while offering growth and enrichment opportunities for every employee.

Our Diversity, Inclusion and Belonging strategy is fueled by Rackers and our leaders across every level of the company, and focuses on these five primary areas:

- Business Practices
- Talent Practices
- Capability Building
- Talent and Brand Recognition
- Compliance

Unique perspectives spark innovative ideas. Research shows that companies who hire employees with diverse backgrounds and unique perspectives usually see increased performance and better business results. While we have a long-established rich and vibrant culture of diversity and inclusion, it is our mission to propel Rackspace Technology to the next level in our journey. Our global Racker Resource Groups lead the charge by providing professional development, leadership opportunities and an environment in which Rackers feel that sense of belonging.

Our global Diversity, Inclusion and Belonging strategy is built on the foundation that all Rackers and potential Rackers, customers, vendors, business partners and guests are treated with respect, and are not

discriminated against based on who they are. Our strategy helps us hire and retain key talent, drive revenue and support the communities in which we serve. Rackspace Technology strives to be a world-class company known for its diverse workforce and its inclusive work environment. Simply put, we want to be **the best place to work.**

Our Diversity, Inclusion & Belonging Statement

Rackspace Technology is committed to advancing diversity and inclusion at every level in our company. We deliver the future for our customers by creating a culture in which Rackers feel a sense of belonging and can thrive by being their authentic whole selves at work.

Social responsibility

Racker Resource Groups

One of the ways we advance diversity, inclusion and belonging is through Racker Resource Groups (RRGs). These groups provide members and leaders with valuable opportunities to grow networks, engage in mentorship, provide support for each other and practice leadership in a safe setting. RRGs provide diversity education, professional development, networking, support and a place for belonging. Some of our RRGs include:



EAST

Elevating Asian Strengths and Talents:

The vision of EAST is to build and grow the appreciation for diversity by celebrating Asian heritages and cultures; serve as a resource for education and promotion of all Asian cultures; create networking opportunities for the members to foster personal and professional growth and visibility; and develop a culture of collaboration, inclusion and trust within Rackspace Technology.



POWER

Professional Organization for Women's Empowerment at Rackspace Technology:

The mission of POWER is to create a community where women thrive and drive greatness at Rackspace Technology through unity, support and growth in an environment of trust, freedom and accountability.



Together With Pride

Supporting LGBTQ+ and educating Rackers and allies:

Together with Pride is to be a resource for all Rackers, regardless of sexual orientation, gender identity or gender expression, by providing opportunities to celebrate, engage and develop at Rackspace Technology and in the local community.



RackParents

RackParents — A network of support for working parents: This global, diverse and topic-centric group offers tools, advice, coffee chats and much more for parents, caregivers and guardians. It is a source of connection, support and information that aims to help Rackers navigate the challenges of being a working parent.



Rackspace Lavender

Supporting mental wellness and physical abilities: The mission of Rackspace Lavender is to foster an inclusive community supportive of mental wellness and physical abilities built on pillars of education and accessibility.



Rackspace Remoters

Bringing together our distributed workforce:

The mission of Rackspace Remoters is to build, engage, enable and support a community of distributed employees at Rackspace Technology. Rackspace Remoters is focused on the inclusion of remote and work-from-home Rackers in all aspects of Rackspace Technology.

At the outset of the COVID-19 pandemic, Remoters were instrumental in helping to transition the organization into a virtual workplace. In addition to technical assistance, Rackspace Remoters provided tips and strategies to ensure each Racker's wellness remained top of mind.



RackVET

Leveraging the talent of our military veterans: RackVET is a group of Rackers who voluntarily come together with the shared goal of making Rackspace Technology an even better place to work through group-initiated activities designed to educate, advocate and celebrate.



RISE

Rackspace Inclusive Support and Empowerment To Lift Black, African and African American Rackers: The mission of RISE is to increase the awareness of cultural diversity and inclusion at all levels of management at Rackspace Technology through a continued commitment to diversity, education and projects using the five-C model: Culture, Career, Communication, Commerce and Community.



VIVA!

Celebrating and promoting our LatinX cultures: The mission of Viva is to develop, inspire and motivate our members while celebrating and promoting awareness of the Hispanic/Latino culture in the community and at Rackspace Technology.

Social responsibility

Employee engagement

Engaged employees are involved in and enthusiastic about their jobs. They are more likely to be more productive, efficient and motivated, and they are invested in the success of the organization. At Rackspace Technology, we define an engaged employee as someone who voluntarily brings their best self to work every day.

Engagement is affected by many factors, such as meaningful work, career growth, empowerment, belonging, recognition, leadership effectiveness and workplace camaraderie. Engagement begins with identifying a Racker's strengths and ensuring that they are the good fit for the role. It continues through giving ongoing guidance, support and resources to ensure the Racker is successful and fulfilled in the role.

Building on our natural strengths

Before their first day of work, each and every Racker takes the CliftonStrengths Assessment to uncover areas of natural talent. When Rackers are able to exercise skills in which they naturally excel, they're likely to be more engaged in their work, give their best, and, in return, pass that contagious engagement on to our customers by delivering Fanatical Experience™.

The strengths philosophy is central to the Rackspace Technology culture. Name tents and security badges prominently display each Racker's top-five strengths so that when they interact with one another, they can take each other's strengths into consideration. As a strengths-based company, we use these important results to better understand ourselves and how we work with our fellow Rackers, customers and partners.

Core Values and Behaviors

Our Core Values establish the baseline expectations we have of each other and help guide us as we work together every day. They are authentic to who we are, and who we need to be. These are the behaviors that Rackers exemplify in our best moments and in our best interactions.



We prioritize excellence:

We're an accountable, disciplined, high-performing company with proven results.



We're customer-driven:

We're proactive, collaborative and committed to success for our customers.



We are experts:

Rackers are passionate learners, embedded in our customers' businesses to develop and deliver unbiased solutions.



We're agile:

We adopt new technologies and evolve services to meet customers where they are in their journey.

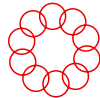

We embrace compassion:

We're one team doing the right thing for our customers, communities and each other.

Rackers are expected to put these principles into action by aligning their behaviors to our Core Values and by embedding them into their ways of working. As our fundamental guiding principles, Rackers can rely on these Core Values and behaviors to help make decisions and set expectations with one another.

Quarterly, we recognize Rackers who exemplify our Core Values by going above and beyond in their efforts to deliver Fanatical Experience™ to the company, their team and our customers. Known as the Racker to the Core Award, recipients of this recognition receive an exclusive jacket, flag, trophy and a monetary gift.



Social responsibility



RackerPulse

RackerPulse is our annual employee survey that helps us understand engagement levels across the organization. It measures key drivers of engagement and allows us to identify and take action on areas where we can improve the Racker experience.

When taking the survey, Rackers rate 21 statements, using a five-point scale, to identify what accelerates or hinders their engagement. Each statement has a comment section that allows the Racker to share additional feedback, ideas and needs. At the end is an open-ended question that provides additional opportunities for Rackers to share what's on their mind.

A third-party AI survey and employee engagement company facilitates the entire RackerPulse survey, analysis and reporting process, housing all responses in its own database to ensure Racker anonymity. Racker responses are compiled and aggregated for a collective voice. The aggregate of ratings and comments are read by managers and leaders up the reporting line, as well as by ELT members so they can understand and take action on the factors that matter most to Rackers.



Spotlight! Recognition Program

Spotlight! is a global, peer-to-peer recognition program delivered by the Achievers Employee Experience Platform™ to recognize Rackers for modeling our core values and delivering on our company priorities. Spotlight! enables Rackers to recognize individuals and teams across the organization in an easy, timely and visible way. Since the launch of Spotlight!, nearly 100,000 peer recognitions have been given by Rackers around the world.

In August 2021, Rackspace Technology was honored to be recognized with an Achievers 50 Most Engaged Workplaces® Award. This award recognizes employers that display leadership and innovation in engaging their workplaces based on Achievers' Eight Elements of Employee Engagement®: Accountability & Performance, Belonging, Equity & Inclusion, Culture Alignment, Manager Empowerment, Professional & Personal Growth, Purpose & Leadership, Recognition & Rewards, and Well-being.



Social responsibility

Career development

Rackspace Technology University Technical Onboarding Program

We're investing in our employees and opening doors to new career paths through our Technical Onboarding Program (TOP). Rackers who are accepted to this full-time, 90-day program get paid to participate in formal learning and certification for cloud engineer, cloud native software engineer, and data engineer roles. Rackers who complete the program will help customers tackle some of their most complex challenges through hands-on and consultative engagements.

Racker Chats: These informal, small-group conversations with senior leaders give Rackers an opportunity to connect with leaders and to ask, share, listen and learn about different disciplines throughout our organization. Racker Chats are Zoom-based and are attended by Rackers around the world.

Rackspace University: Investing in the development of Racker expertise enhances our ability to deliver Fanatical Experience™ for our customers. Rackspace University offers a variety of training and development resources to help grow Rackers' skill sets and deliver the future for our customers. With 9,500+ technical certifications across AWS, Microsoft® Azure®, Google Cloud, Cisco®, Oracle®, Red Hat®, SAP, VMware® and other solutions, Rackers find Rackspace University to be an invaluable resource in the development of their careers.

52+ Learning Hours: To build on the learning foundation provided by Rackspace University and to live our Core Value of Expertise, we've introduced 52+ Learning Hours. This program encourages Rackers to nurture their passions by accruing at least 52 hours toward their annual learning and career development goals. There are numerous ways through which to accrue these hours, including formal training, problem solving for customers, learning new skills for a new role, and through coaching, mentoring and peer relationships.



Rookie-O

Each month, new hires (referred to as "Rookies") take part in three days of virtual, instructor-led learning that immerses them into the Rackspace Technology culture and business. Rookie-O is a fun, interactive and welcoming way for all new hires to:

- Learn the business strategy and structure of Rackspace Technology
- Gain a deeper understanding of our basic offerings and services
- Learn the behaviors associated with our Core Values

Rookies are assigned to teams, and compete against one another for points as they participate and learn through presentations delivered by leaders from departments across the company. At the end of orientation, team members create and deliver a culture presentation. During Rookie-O graduation, at which Rackers from across the company welcome new members into the Rackspace Technology family, the team that accumulated the most points is awarded the coveted title of "Top Team."

The Stevie Awards for Great Employers has recognized Rackspace University as the Onboarding Team of the Year in 2018.



Racker spotlight:

Katja Zurcher

Sr. Global Trainer, Rackspace Technology

Converting our award-winning orientation program to an online experience

Katja Zurcher is a Senior Global Trainer as well as the program owner of Rackspace University's global onboarding program Rookie-O. In response to the work-from-home and travel restrictions set into motion by the Covid-19 pandemic, Katja transformed Rookie-O into a completely virtual onboarding experience. The transition led to 95% of participants stating that they had an even higher opinion of Rackspace Technology after completing the program.

"Rookie-O is one of the first experiences new hires have at Rackspace Technology," says Katja. "It's such a unique onboarding experience that everyone — even the CEO — has participated in. For me, it's so rewarding to watch new friendships form within each class as new hires from teams across the company get a feel for how fun and rewarding a career here can be."

Social responsibility

Cultivating new careers through internships

Rackspace Technology internships offer students and recent graduates in the U.S. and U.K. the opportunity to work and live within our culture while learning about the technology landscape in a fast-growing market. Interns quickly learn about the challenges that our clients and teams face, and how to contribute to solving those challenges as effective team members — all while growing their networks and building a launch pad for their careers.

Whether students are pursuing careers in fields such as software development, engineering, marketing, support or sales, an internship provides valuable, hands-on experience in an innovative, fast-paced environment that will challenge their skills and shape their ability to excel in the tech industry.

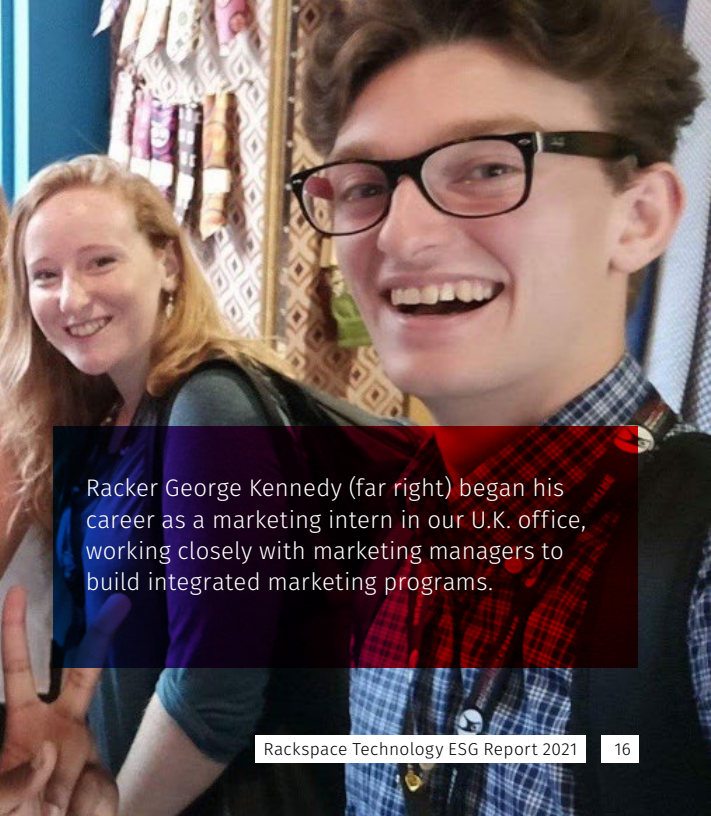
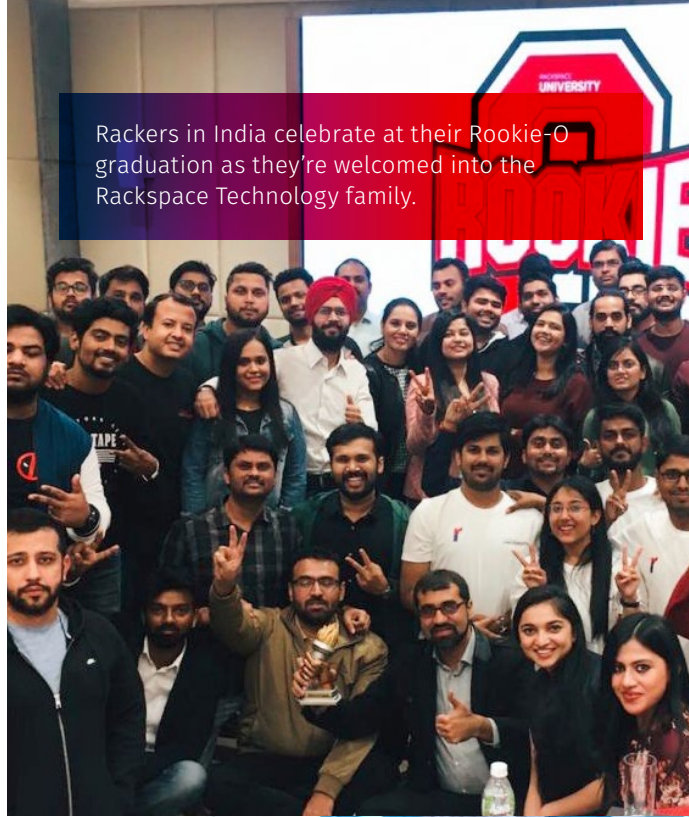

Photographs on the right are from pre-pandemic events.

Social responsibility

Our focus on equality

Best Places to Work for LGBTQ+ Equality

In January of 2021, Rackspace Technology received a perfect score on the Human Rights Campaign Foundation's 2021 Corporate Equality Index. This was the fourth year in a row that the company received this honor.

For nearly 20 years, the Human Rights Campaign's Corporate Equality Index has served as the national benchmarking tool for corporate policies and practices pertinent to LGBTQ+ employees. The Corporate Equality Index rates companies on detailed criteria falling under four central pillars:

- Non-discrimination policies across business entities
- Equitable benefits for LGBTQ+ workers and their families
- Support for an inclusive culture
- Corporate social responsibility

Businesses across the country use the HRC's Corporate Equality Index as a guide to ensure their existing policies and benefits are inclusive of the LGBTQ+ workforce and their families. Rackspace Technology is proud to have consistently earned high ratings on this index.

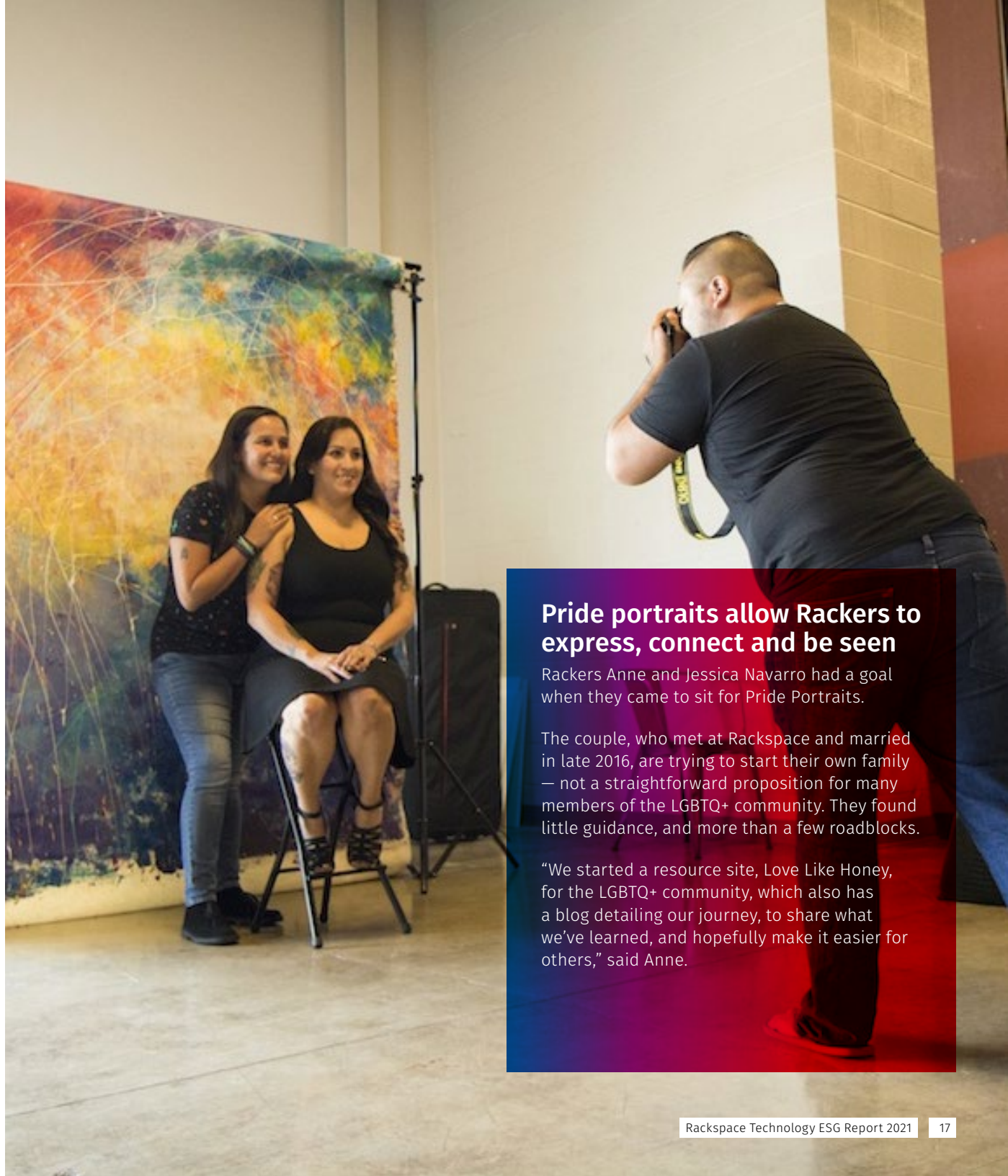

Pride portraits allow Rackers to express, connect and be seen

Rackers Anne and Jessica Navarro had a goal when they came to sit for Pride Portraits.

The couple, who met at Rackspace and married in late 2016, are trying to start their own family — not a straightforward proposition for many members of the LGBTQ+ community. They found little guidance, and more than a few roadblocks.

“We started a resource site, Love Like Honey, for the LGBTQ+ community, which also has a blog detailing our journey, to share what we’ve learned, and hopefully make it easier for others,” said Anne.



99.5% of our global office-based workforce has continued to work from home

Social responsibility

An update on COVID-19

In March 2020, when it became clear that COVID-19 was advancing rapidly to become a pandemic that would change the way every one of us lived and worked, Rackspace Technology was ready. The health and safety of our Rackers immediately became our top priority. Ahead of most governments and other companies, we made the decision to have nearly all Rackers work from home. Since then, 99.5% of our global office-based workforce has continued to work from home.

For those Rackers who continued to work onsite in our data centers, we quickly implemented new protocols designed to protect their health. These included minimizing non-essential visits, utilizing questionnaires for access, conducting temperature scans, prioritizing workloads, employing social distancing for workstations, disinfecting common areas between shifts and requiring masks or other PPE, as necessary.

During the early days of the pandemic, we understood that it would be difficult to source masks in many of our locations around the globe. So, we purchased and sent 100,000 non-surgical masks to support Rackers and their families all around the world.

Today, **Racker wellness continues to be our #1 priority.** Rackspace Technology has evolved physical health programs and developed new mental and emotional wellness programs to better serve and support our Rackers.

In addition to caring for the health and safety of Rackers, we began to look for ways we could help those organizations that support our communities. To that end, we initiated our first company-wide donation match program, matching Racker donations to COVID-19 relief organizations and other non-profit organizations that provide valuable services and support to local communities. During this two-week campaign, Rackspace Technology and its employees donated more than

\$200,000 toward the COVID-19 relief efforts of over 360 organizations around the globe.

To promote physical fitness among our teams, we launched “Spring into Motion,” an online health initiative where Rackers can track their physical activities, compete for prizes, and receive valuable health and wellness tips. Spring into Motion was also utilized to support COVID-19 relief organizations. By tabulating total steps taken by employees, we were able to raise an additional \$10,000 for non-profit organizations supporting those impacted by the pandemic.

Simultaneously, we expanded our Employee Assistance Program globally to enable Rackers in all locations to have access to mental health professionals and other resources. We also partnered with Whil, a mental and emotional wellness and meditation application that we made available to every Racker.

Our global guest speaker series engaged Rackers through virtual events. For example, motivational speaker and New York Times best-selling author Dr. Angela Duckworth shared how grit and resiliency contribute to achievement.

Also, to show our appreciation and help keep employee engagement levels high during the pandemic, Rackspace Technology conducted a gift drop through an interactive online platform that allowed our employees to select a special gift from a menu of options curated by country.

We were very pleased to be recognized by Everbridge, a security consulting partner, with the **“Going Above and Beyond” Impact Award** for our response to COVID-19 and focus on Racker wellness through programs in health and safety as well as engagement, communications and mental well-being.



Environmental

Environmental

Our conservation strategy

Our environmental strategy is simple: We aspire to give more than we take from our planet, and we support innovative technologies that change the energy industry for the better. We do this through renewable energy, conservation and advocacy, as detailed in our Global Energy Policy.

Our commitment to net zero carbon emissions

Following our 2020 IPO, Rackspace Technology has committed to achieving net zero carbon emissions by 2045. That's five years ahead of the U.N. Paris Agreement on Climate Change ambition to limit the global warming of the planet to 1.5 degrees Celsius, compared to pre-industrial levels (net zero by 2050).

Reaching this goal will require a focused effort across our organization. Our leaders, teams and partners are encouraged to incorporate environmental responsibility into their daily operational decision-making processes. We expect all Rackers and each of our partner organizations to perform above the minimum standard of the law and to continually revisit their sustainability performance to ensure efforts are being made to improve results.

Our commitment to the environment is strong, and we're already making improvements. We've begun the process of automating our large facilities with smart, energy-saving features that, so far, have resulted in a 2,000-kilogram reduction of CO₂ in our Hayes, U.K. location. And we don't plan to stop there. In fact, we have assembled a cross-functional team to more clearly define our ESG-related goals so we can better measure our impact in the coming months.

Through the delivery of cloud services to our customers, Rackspace Technology is contributing to an overall

reduction of energy consumption. By moving companies to shared resources and facilities, cloud adoption helps to reduce the number of duplicate, energy-hungry data centers across an enterprise.

In addition, customers who decide to move their data to the cloud with Rackspace Technology have a variety of options that can help them further reduce their carbon footprint. The sustainability and financial benefits from cloud migration varies, depending on which cloud a customer selects, the level of cloud optimization and whether the customer uses any sustainability innovations powered by the cloud.

Measuring our greenhouse emissions

We have prepared a greenhouse gas (GHG) emissions inventory (scope 1, 2 and partial 3) every year since 2008 for all of our operations worldwide. Having a better understanding of our footprint allows us to identify high-impact efficiency projects that help us conserve resources and benchmark outcomes. For example, we use specialized air filters in our London office to reduce carbon dioxide equivalent (CO₂e) by 2,000 kilograms per year.

We also participate in the Climate Change Agreement (CCA), which is a U.K. voluntary scheme for energy-intensive industries, and we have responded to every CDP Climate Change Survey since 2011. In addition, we operate three ENERGY STAR® or LEED-certified facilities.

Environmental data

The Carbon Disclosure Project (CDP) is a non-profit reporting entity providing a platform for companies to disclose their environmental impact while also creating a network for investors and companies to research and compare the performance of prospective companies, customers and suppliers. Our participation in the annual CDP survey provides customers and investors with a transparent and streamlined view of both our emissions data and our environmental sustainability standards.

Greenhouse gas emissions: reporting year 2020

Scope 1	522 metric tons CO ₂ e
Scope 2 (location-based)	122,408 metric tons CO ₂ e
Scope 2 (market-based)	114,909 metric tons CO ₂ e
Scope 3 (business travel)	1.127 metric tons CO ₂ e

Environmental

How we minimize waste

Conservation of our planet's natural capital comes in many forms, from responsibly disposing of data center assets to using sustainable materials within our workspaces. We've found creative ways to minimize waste on our campuses, such as composting coffee grounds and shipping pallets, refurbishing retired IT equipment for aftermarket use, and collecting HVAC condensate to maintain landscaping and operate cooling towers.

In 2019, we evaluated our energy strategy and opted to focus resources and efforts on energy reduction activities and projects, instead of our previous strategy of purchasing carbon offsets. We have continued to purchase 100% Renewable Energy Guarantees Origin (REGO)-backed energy to cover consumption in our Slough, U.K. data center and our London headquarters.

We have also invested in and are deploying smart building automation systems in five locations globally, including two corporate offices (San Antonio and London) and three data centers (London, New Jersey and Kansas City). These systems will drive reduced energy consumption in each of these locations through building control systems that provide the ability to efficiently manage light, heat and cooling zones based on operational demand. The automation system in our San Antonio office also shuts down chillers when temperature and humidity conditions allow for cooling of the site using outside air.

One of our biggest energy-saving initiatives is open air free cooling, which we employ in our Sydney, Australia and Slough, U.K. data centers. Open air free cooling is a technique that leverages the natural climatic conditions in those regions to provide significant energy savings. Essentially, we can meet the cooling requirements of the equipment within these facilities using just fans instead of more energy-intensive mechanical cooling systems.

Water reduction initiatives

Rackspace Technology continues to use and outfit restrooms and break areas with water efficient fixtures such as dual-flush commodes, low-flow, or waterless urinals and faucet aerators.

Water recycling and reuse

Rackspace Technology utilizes condensate generated by our HVAC units to help maintain landscaping and feed water to operate the cooling towers within our corporate headquarters. We also use stored rainwater for all flushing systems within the London office restrooms.

Recycling initiatives

Rackspace Technology participates in recycling programs that address paper, aluminum, plastic, cardboard, glass and e-waste. In addition, we have composting and battery recycling programs in place at many sites.

Reducing the amount of waste we send to landfills

Rackspace Technology has some 100% packaging waste recycling and zero landfill sites where all waste is reused or recycled. This includes working with technology equipment suppliers to ship certain equipment or components in the supplier's reusable crates rather than in standard throwaway cardboard packaging.

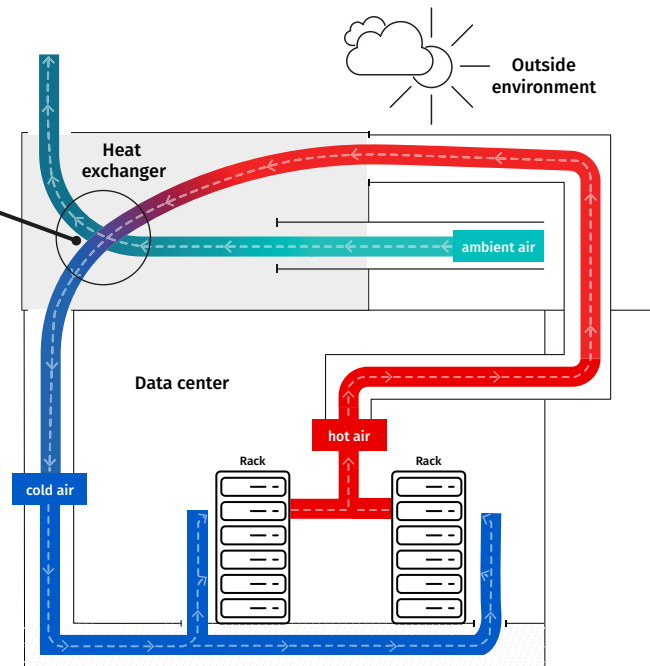
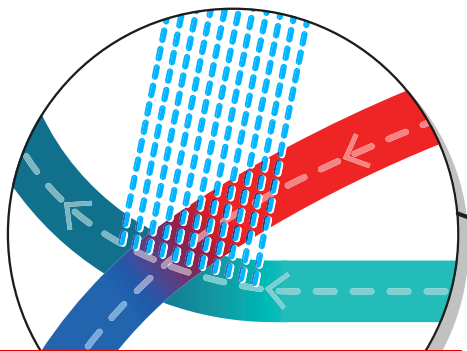

One of our biggest energy-saving initiatives is open air free cooling, employed in our Sydney, Australia and Slough, U.K. data centers. Central to this design is a heat exchanger which uses cool outside air to reduce the temperature of hot air from the data center. When the outside air is warmer than the air in our data center, water is sprayed over the heat exchanger to cool the data center air.

Environmental

Sustainability is a core focus of our partnerships

Rackspace Technology partners with a large number of outside suppliers in the delivery of services to our customers. We're proud to have relationships with some of the technology industry's best and brightest. In the spirit of doing our part to preserve the environment, our suppliers are encouraged to incorporate environmental responsibility into their operational decision-making processes, to perform above the minimum standard of the law and continually revisit their sustainability performance to ensure efforts are being made to improve results.

Stewardship: We value companies who measure and manage their resource use and demonstrate stewardship in minimizing their impact to humans and the planet.

Responsible sourcing: Suppliers are expected to take a holistic view and consider social, environmental and governance aspects of decisions on upstream and downstream suppliers, materials and services.

Environmental management system for supplier operations: Suppliers must take a proactive and progressive approach to minimizing negative impacts to the environment. Suppliers should have environmental policies and standards and must comply with all environmental laws and regulations. Factories must continuously monitor their production processes, including those related to emissions, discharges and disposal of waste.

Hazardous waste: Suppliers must manage all hazardous materials capable of posing a threat to health and safety by ensuring all materials are safely and appropriately handled and disposed. Suppliers should ensure that all personnel are trained on how to handle hazardous material.

Wastewater and solid waste emissions: Suppliers must monitor, treat, control, and manage wastewater and solid waste and dispose of it properly.

Air emissions and pollution prevention: Suppliers must ensure air emissions are properly disposed of upon release. To promote a sustainable environment, suppliers should strive to reduce their resource consumption and use, and implement improvement plans for waste reduction, recycling and energy conservation policies.

Conflict minerals: Rackspace Technology suppliers must not use "conflict minerals" as defined by relevant laws. Furthermore, all applicable suppliers must meet the conflict mineral reporting requirements as required by the Dodd-Frank Wall Street Reform and Consumer Protection Act and the Securities and Exchange Commission.

Designed for sustainability: Suppliers must take steps to consider all impacts of goods and services used and produced throughout the product/service lifecycle (design, sourcing, manufacturing, shipment, operation re-use, recycling and disposal).



Rack Gives Back

Armed with buckets and litter-picker sticks, Rackers in Australia pull trash from Sydney Harbour while learning how to kayak.



Governance

Governance

Board oversight of sustainability efforts

Rackspace Technology is governed by a board of directors, a majority of whom are independent of our organization. Our Board of Directors includes respected leaders from many of the world's top technology and financial services companies. Through its oversight, the Board helps us advance our mission to embrace technology, empower customers and deliver the future.

Board members are fully committed to the oversight of current and future ESG initiatives. As we march toward achieving net zero carbon emissions by 2045, the Board will continue to engage with our Executive ESG committee to steer our ESG initiatives.

Our approach to risk management

Rackspace Technology consults with internal and external subject matter experts to identify climate-related risks and manage the processes associated with them. Internally, two primary risk mitigation teams, the Business Continuity Team and the Supply Chain Contingency Team, address climate-related risks. These teams are responsible for prioritizing any current risk based on business impact, severity and detectability. High-impact material risks are escalated to the Vice President of Business Operations. This internal audit is conducted annually or as a significant risk arises.



Holly Windham

Executive Vice President, Chief Legal and People Officer & Corporate Secretary, Rackspace Technology

Governance

Data privacy and cybersecurity

We care about protecting privacy because it's our duty to protect the trust and confidence we've built with our customers, partners and Rackers. In addition to staying ahead of emerging privacy concerns and risks, we provide Rackers with regular training on potential privacy and data protection risks. We also offer a complete menu of products and services that customers can purchase to help meet their own data privacy, protection and compliance needs — across every industry vertical.

Cloud security solutions

The constant evolution of threats and the race for more sophisticated tools to combat them means the security landscape changes quickly. The goal is continuous improvement, but these factors make it challenging to maintain a cutting-edge security posture or to develop deep expertise. Many IT teams struggle, getting caught in an ongoing cycle of operating reactively, which limits their ability to look ahead in a proactive manner.

To help our customers proactively protect their organizations and respond quickly to emerging security threats, we offer an extensive range of security solutions and services, including:

Advanced Monitoring & Resolution for Security:

24x7x365 security technology health monitoring, security automation, operational support and help desk support

Application Security: Protection against web application breaches using enterprise-class WAF, DDoS and CDN solutions

Data Protection: Access policy and encryption tools, key management automation and clearly defined security processes to help ensure the highest levels of data protection

Network Security: Security solutions and custom network configurations designed to protect on-premises and cloud environments, along with around-the-clock support from certified security experts

Detection and Mitigation: Around-the-clock Security Operation Center (SOC) services designed for Security Information and Event Management (SIEM), rapid response and remediation, proactive cyber hunting, audit-ready compliance and cloud native security

Security Strategy: Expert-led assessment and consultation services designed to ensure security resiliency through posture assessments, risk assessments, compliance assistance, penetration testing and additional fortification services

Rackspace Elastic Engineering for Security: On-demand access to security expertise from every discipline — management, architecture, engineering, compliance, analysts — for help fortifying modern and cloud native architectures

Zero Trust: End-to-end protection for sensitive data through identity verification at multiple points of network and application access



A highly skilled Racker in one of our Security Operations Centers monitors the threat landscape in real time.

Governance

Physical security and compliance controls

At Rackspace Technology, we're known for our specialized expertise and 24x7x365, results-obsessed customer service. And we extend this commitment to excellent service to our world-class data centers and our industry-leading SLAs.

We offer our customers a wealth of security and compliance services. Doing so requires that we implement leading security and compliance technologies, and that we provide these services based on protocols that meet or exceed industry best practices. To that end, we've established rigorous security and compliance controls at each of our 19 data centers around the world.

Our highly trained engineers monitor our systems around-the-clock, constantly overseeing the security and uptime of our infrastructure. To create a highly resilient environment for our customers' business-critical applications and data, we've built in multiple layers of redundancy. Our physical security, power, cooling and networks are each at least N+1 redundant.

These cutting-edge, interconnected data centers are strategically located in the world's most influential technical and financial markets to provide customers with global reach, scale and organizational agility, wherever they are and whenever they need it.

Data center physical protections

At all of our data centers, access is limited to authorized personnel only. Access to each facility is controlled through a combination of badges and biometric scanning. Each facility is monitored through video surveillance, and an independent, third-party firm conducts an annual physical security audit of each facility.

Data center environmental controls

Each of our data centers is engineered and maintained to help ensure uptime. We do this through a combination of features, including dual power paths into each facility, uninterruptable power supplies (N+1 or greater), the installation and maintenance of diesel generators on-site, and through a sophisticated fire suppression, smoke and flood detection system.

Network infrastructure security

Our network infrastructure is designed and managed to deliver high-performance bandwidth. Our experts have properly trunked and secured our network cables, and our network as a whole is proactively monitored and managed to deliver guaranteed uptime backed by service-level agreements.

Personnel

Access to our data centers is extremely limited. To help ensure the highest levels of security, all data center employees are carefully screened and have passed rigorous background checks. Data center personnel also commit to non-disclosure and confidentiality agreements, and undergo security awareness training on an annual basis.

Operations security

Our data center operations conform to:

- ISO 27001/2-based policies and annual reviews
- Documented change management procedures
- Secure document and media destruction policies
- Incident management and business continuity plans
- Continuous monitoring and third-party reviews

Security Operations Centers

Our global Security Operations Centers (SOCs) are staffed with security analysts who are Global Information Assurance Certified (GIAC) and Global Certified Incident Handlers (GCIH) certified and focused on analyzing security alerts and providing around-the-clock incident response. Our SOC services are designed to help protect all customer environments, no matter where applications and data are hosted. At the personnel level, our security force includes more than 400 network and security experts with over 500 network and security certifications.

Law enforcement requests

Rackspace Technology occasionally receives legal demands for customer data from government and civil litigation parties. We require these parties to follow the applicable laws, rules and procedures for requesting customer data. In addition, Rackspace Technology will notify customers prior to disclosing the requested data, unless otherwise prohibited by law. We believe that customers should control their own data, and we do not give any government (including law enforcement or other government entities) direct or unfettered access to customer data.



Governance

Rackspace Technology Code of Conduct and Business Ethics

Rackspace Technology is known throughout our industry for exceeding expectations: those of our customers, partners, communities and fellow team members. As we have expanded into new products and new regions, we have built a global reputation for lawful and ethical conduct, or “doing the right thing.” We achieve this by having a talented workforce that continuously holds itself to the highest standards.

The Rackspace Technology Code of Conduct is designed to support our efforts and guide our performance to meet the highest ethical standards within the workplace. It helps us ensure we comply with regulations and expectations in all of the places where we do business.

All employees are required to complete yearly Code of Conduct training. The Code of Conduct applies to all employees, including the CEO, CFO, principal accounting officer and controller, and other persons performing similar functions. Each of us is responsible for understanding and upholding the Code as we deliver Fanatical Experience® to our customers, communities and each other.

Our Global Speak-Up Policy

As part of our commitment to creating and maintaining an ethical and honest work environment, Rackspace Technology has a formal whistleblower system in place. Employees may raise concerns about any misconduct or non-compliance through a third-party hotline or an online portal, any time of day. Interpreters are available upon request, and employees can remain anonymous.

Our statement against modern slavery

Rackspace Technology is committed to upholding fundamental human rights and believes that all human beings should be treated with dignity, fairness and respect. We will only engage suppliers and hire contractors who demonstrate a serious commitment to the health and safety of their workers and operate in compliance with human rights laws. Rackspace Technology does not use or condone the use of slave labor or human trafficking, and we denounce any degrading treatment of individuals or unsafe working conditions.

Governance

ISO standards

Rackspace Technology is certified to ISO's world-class international standards and complies with, and has received certification in, a variety of ISO standards across our global organization.

For more than 60 years, the International Organization for Standardization (ISO) has been working to establish global standards for quality, safety, security and efficiency. With the participation of over 100,000 experts, 165 member countries and 700 partner organizations, ISO creates standards that touch nearly every aspect of life — from quality management, to IT security and risk management, to occupational health and safety.

ISO has designed its IT security management standards to help organizations secure their sensitive information, including financial records, intellectual property, employee details and customer data.

Rackspace Technology complies with, and has received certification in, a variety of ISO standards across our global organization. These include:

ISO/IEC 27001

The ISO/IEC 27001 standard provides a framework for businesses seeking to establish, implement, maintain and continually improve an information security management system (ISMS). With an ISMS, businesses can secure their sensitive information through a risk management process that combines people, processes and IT systems. This certification is subject to ongoing external assessments, with a full reassessment occurring every three years.

Our ISO 27001 certification applies to all of our data center locations. Our ISO 27001 certificate number is IS 636168.

ISO 9001

The ISO 9001 standard provides guidance for companies that want to consistently meet and exceed customer requirements. It's based on a number of quality management principles, including a strong customer focus, to help ensure that customers receive consistently high-quality products and services. This standard closely aligns with Fanatical Support® — the results-obsessed customer service and deep technical expertise that's been part of our DNA since 1999.

Our U.K. management, delivery and support functions are certified to ISO 9001 standards.

ISO 14001

The ISO 14001 standard provides a framework for businesses that want to enhance their environmental performance, including energy and waste management, in a systematic manner.

Rackspace Technology has implemented an Environmental Management System (EMS) that has earned ISO 14001 certification for our data centers and offices in Australia and the U.K. This certification is subject to ongoing external assessment by the British Standards Institution (BSI), with a full re-assessment occurring every three years.

To learn more, read our [Commitment to Occupational Health and Safety & Environmental Sustainability Policy](#). Our ISO 14001 certificate number is EMS 581182.

OHSAS 18001

Rackspace Technology takes its environmental and workplace responsibilities seriously, from working to ensure we provide a safe and healthy working environment for our employees, to our legal and moral commitments to the regions we serve.

Our [Commitment to Occupational Health and Safety & Environmental Sustainability Policy](#) attests to these commitments. Our BS OHS 18001 certificate number is OHS 587454.

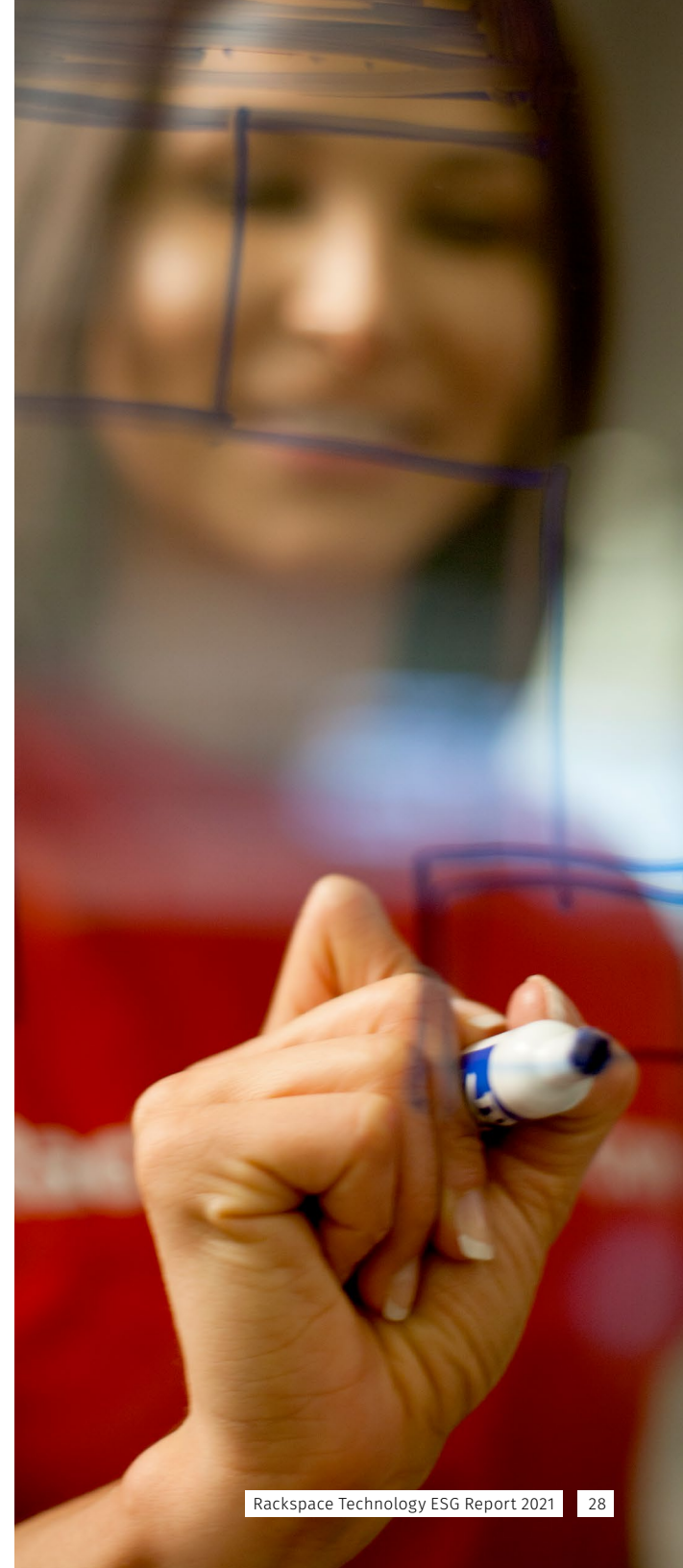



Indices & Policies

Indices

Sustainability Accounting Standards Board (SASB) Index

Topic	Accounting metric	Category	Unit of measure	SASB code	Reference
Environmental Footprint of Hardware Infrastructure	(1) Total energy consumed, (2) percentage grid electricity, (3) percentage renewable	Quantitative	Metric tons CO2e	TC-SI-130a.1	Pages 20 , 21
	Discussion of the integration of environmental considerations into strategic planning for data center needs	Discussion and Analysis	n/a	TC-SI-130a.3	Pages 20 , 21 , 28
Data Privacy & Freedom of Expression	Description of policies and practices relating to behavioral advertising and user privacy	Discussion and Analysis	n/a	TC-SI-220a.1	Page 25 Global Acceptable Use Policy
	(1) Number of law enforcement requests for user information, (2) number of users whose information was requested, (3) percentage resulting in disclosure	Quantitative	Number, Percentage (%)	TC-SI-220a.4	Page 26 Law Enforcement Disclosure Report
Data Security	Description of approach to identifying and addressing data security risks, including use of third-party cybersecurity standards	Discussion and Analysis	n/a	TC-SI-230a.2	Pages 26 , 28 Rackspace Technology Security Vulnerability Reporting
Managing Systemic Risks from Technology Disruptions	Description of business continuity risks related to disruptions of operations	Discussion and Analysis	n/a	TC-SI-550a.2	Pages 24 , 28



Rack Gives Back

Rackers in Switzerland put their skills to work building animal shelters at a local pet rescue.

Indices

Task Force on Climate-Related Financial Disclosures (TCFD) Index

TCFD Recommendations

Reference

Governance

- (a) Describe the board's oversight of climate-related risks and opportunities
- (b) Describe management's role in assessing and managing climate-related risks and opportunities

See 2021 CDP Climate Change Survey Response¹

Strategy

- (a) Describe the climate-related risks and opportunities that the organization has identified over the short, medium, and long term.
- (b) Describe the impact of climate-related risks and opportunities of the organization's businesses, strategy, and financial planning.
- (c) Describe the resilience of the organization's strategy, taking into consideration different climate-related scenarios, including a 2°C or lower scenario.

See 2021 CDP Climate Change Survey Response¹

Risk Management

- (a) Describe the organization's processes for identifying and assessing climate-related risks.
- (b) Describe the organization's processes for managing climate-related risks.
- (c) Describe how processes for identifying and assessing, and managing climate-related risks are integrated into the organization's overall risk management.

See 2021 CDP Climate Change Survey Response¹

Metrics & Targets

- (a) Disclose the metrics used by the organization to assess climate-related risks and opportunities in line with its strategy and risk management process.
- (b) Disclose Scope 1, Scope 2, and, if appropriate, Scope 3 greenhouse gas (GHG) emissions, and the related risks.
- (c) Describe the targets used by the organization to manage climate-related risks and opportunities and performance against targets.

See 2021 CDP Climate Change Survey Response¹

1. Available upon publication to customers and investors via [CDP Portal](#).



Rack Gives Back

U.K. Rackers participate in the annual Hour of Code campaign, expanding access to computer science in schools.

Policies

Forward-looking statements

Rackspace Technology has made statements in this ESG Report and other reports, filings and other public written and verbal announcements that are forward-looking and therefore subject to risks and uncertainties.

All statements, other than statements of historical fact, included in this document are, or could be, “forward-looking statements” within the meaning of the Private Securities Litigation Reform Act of 1995 and are made in reliance on the safe harbor protections provided thereunder.

These forward-looking statements relate to anticipated financial performance, management’s plans and objectives for future operations, business prospects, outcome of regulatory proceedings, market conditions, our ability to successfully respond to the challenges posed by the COVID-19 pandemic and other matters. Any forward-looking statement made in this presentation speaks only as of the date on which it is made. We undertake no obligation to publicly update or revise any forward-looking statement, whether as a result of new information, future developments or otherwise.

Forward-looking statements can be identified by various words such as “expects,” “intends,” “will,” “anticipates,” “believes,” “confident,” “continue,” “propose,” “seeks,” “could,” “may,” “should,” “estimates,” “forecasts,” “might,” “goals,” “objectives,” “targets,” “planned,” “projects” and similar expressions. These forward-looking statements are based on management’s current beliefs and assumptions and on information currently available to management.

Rackspace Technology cautions that these statements are subject to risks and uncertainties, many of which are outside of our control, and could cause future events or results to be materially different from those stated or implied in this document, including among others, risk factors that are described in Rackspace Technology, Inc.’s Registration Statement on Form S-1, Annual Reports on Form 10-K, Quarterly Reports on Form 10-Q, Current Reports on Form 8-K, and other filings with the Securities and Exchange Commission, including the sections entitled “Risk Factors” and “Management’s Discussion and Analysis of Financial Condition and Results of Operations” contained therein.

Our policies and statements

[ISO Certifications](#)

[Global Energy Policy](#)

[Code of Conduct](#)

[Supplier Code of Conduct](#)

[Diversity Website Disclosure](#)

[Global Privacy Policy Statement](#)

[Security Vulnerability Reporting](#)

[Acceptable Use Policy](#)

[Commitment to Security Policy](#)

[Global Speak Up Policy](#)

[Modern Slavery Policy](#)

[Law Enforcement Disclosure Report](#)

About Rackspace Technology

Rackspace Technology is the multicloud solutions expert. We combine our expertise with the world's leading technologies — across applications, data and security — to deliver end-to-end solutions. We have a proven record of advising customers based on their business challenges, designing solutions that scale, building and managing those solutions, and optimizing returns into the future.

As a global, multicloud technology services pioneer, we deliver innovative capabilities of the cloud to help customers build new revenue streams, increase efficiency and create incredible experiences. Named a best place to work, year after year according to Fortune, Forbes, and Glassdoor, we attract and develop world-class talent to deliver the best expertise to our customers. Everything we do is wrapped in our obsession with our customers' success — our Fanatical Experience® — so they can work faster, smarter and stay ahead of what's next.

Learn more at www.rackspace.com or call 1-800-961-2888.

© 2021 Rackspace US, Inc. :: Rackspace®, Fanatical Support®, Fanatical Experience® and other Rackspace marks are either service marks or registered service marks of Rackspace US, Inc. in the United States and other countries. All other trademarks, service marks, images, products and brands remain the sole property of their respective holders and do not imply endorsement or sponsorship.

THE INFORMATION CONTAINED IN THIS DOCUMENT IS A GENERAL INTRODUCTION TO RACKSPACE TECHNOLOGY SERVICES AND DOES NOT INCLUDE ANY LEGAL COMMITMENT ON THE PART OF RACKSPACE TECHNOLOGY.

You should not rely solely on this document to decide whether to purchase the service. Rackspace Technology detailed services descriptions and legal commitments are stated in its services agreements. Rackspace Technology services' features and benefits depend on system configuration and may require enabled hardware, software or additional service activation.

Except as set forth in Rackspace Technology general terms and conditions, cloud terms of service and/or other agreement you sign with Rackspace Technology, Rackspace Technology assumes no liability whatsoever, and disclaims any express or implied warranty, relating to its services including, but not limited to, the implied warranty of merchantability, fitness for a particular purpose, and noninfringement.

Although part of the document explains how Rackspace Technology services may work with third party products, the information contained in the document is not designed to work with all scenarios. any use or changes to third party products and/or configurations should be made at the discretion of your administrators and subject to the applicable terms and conditions of such third party. Rackspace Technology does not provide technical support for third party products, other than specified in your hosting services or other agreement you have with Rackspace Technology and Rackspace Technology accepts no responsibility for third-party products.

Rackspace Technology cannot guarantee the accuracy of any information presented after the date of publication.

Rackspace-Technology-ESG-Report-2021-V11 :: November 11, 2021